

## SWF/KS-Single Head



### Optional Devices

Sequin Device



Cording Device



Boring Device



Pocket Frame



### Machine Specifications

Max Speed	Normal	1,200 spm
	Cap	1,000 spm
Embroidery Field	Tubular	520 x 360 (mm)
	Cap	360 x 75 (mm)
	Border	520 x 360 (mm)
Operation Panel	10.4" Full Touch LCD	
Power Supply	100~240V , 50Hz / 60Hz	
Power Consumption	120W	

### Dimensions

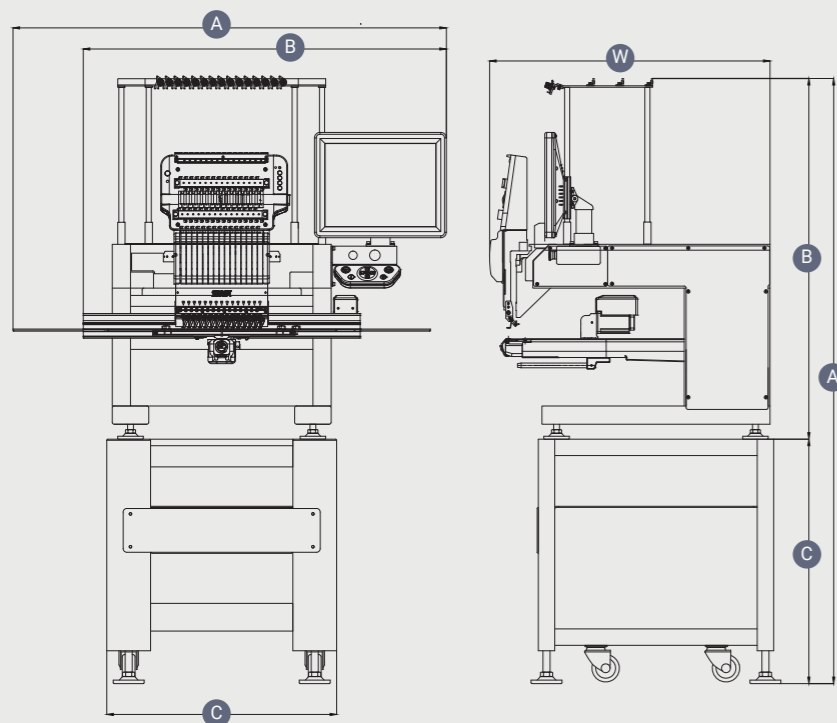

<b>Width</b>	A. 1,200mm B. 1,000mm C. 630mm
<b>Depth</b>	W. 770mm
<b>Height</b>	A. 1,700mm B. 1,000mm C. 700mm
<b>Weight</b>	Machine: 100Kg Stand: 40kg

\* Machine specifications are subject to change without prior notice.

# SWF KS Single Head Series

Smart Single-Head Automatic  
Embroidery Machine



#39, SAEBEOL-RO, BUPYEONG-GU, INCHEON, REPUBLIC OF KOREA  
**T.82.32.580.5600 F. 82.32.584.3015**  
**Sales.** sales@sunstar.co.kr **Service.** swfservice@sunstar.co.kr  
**Parts.** swfcsparts@sunstar.co.kr **www.swfkorea.co.kr**



## New Technology

SWF

### Arm Angle Improve

Compared to the old SWF machines, the angle improved from 44 degrees to 54 degrees.

Working on cap embroidery, Big advantageous in that it does not interfere with the cap brim. Implemented of the highest quality machine of cap embroidery.

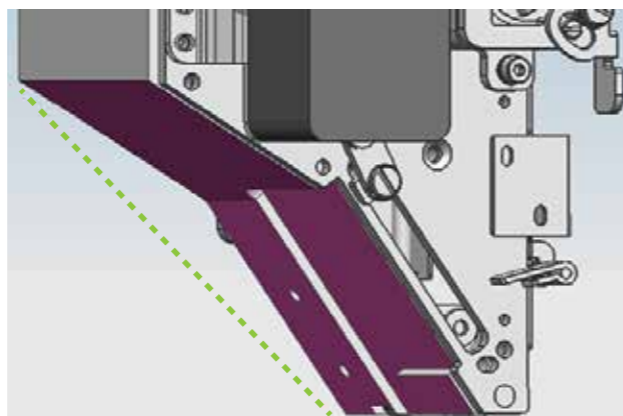

### Easy Change Cap System (Factory Option)

The Cap Frame has been re-designed and is lighter and stronger. Switching between cap frame and tubular frames is quick and easy (using thumb screws) - no tools required.

This allows the users to efficiently manage their working hours and improve productivity by operating machine in high-speed.



### Slim Cylinder Arm

Redesign of the cylinder arm improves the quality of embroidering on products

Reduction of the cylinder bed circumference to 170mm

Reducing working space between the needle plate and cap frame.

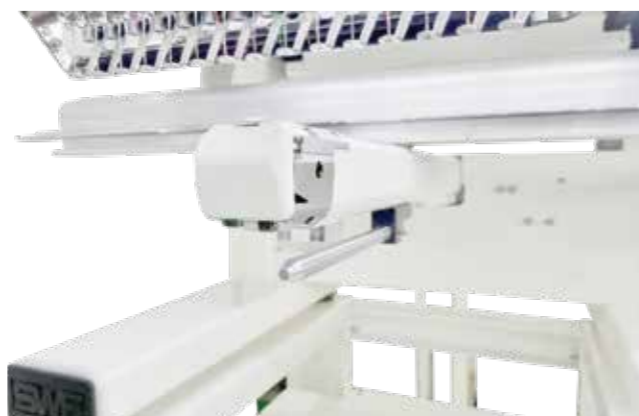

## SWNS

SWF "SWNS" (Sunstar World Networking System) allows you to network your SWF embroidery machines with a Wireless system. Send and download designs to and from your Embroidery machines via WiFi connectivity. Connect up to 200 machines. Reduce machine down time and increase productivity. (Compatible with SWF Embroidery Machines MAS, KE, KS, KX Series)

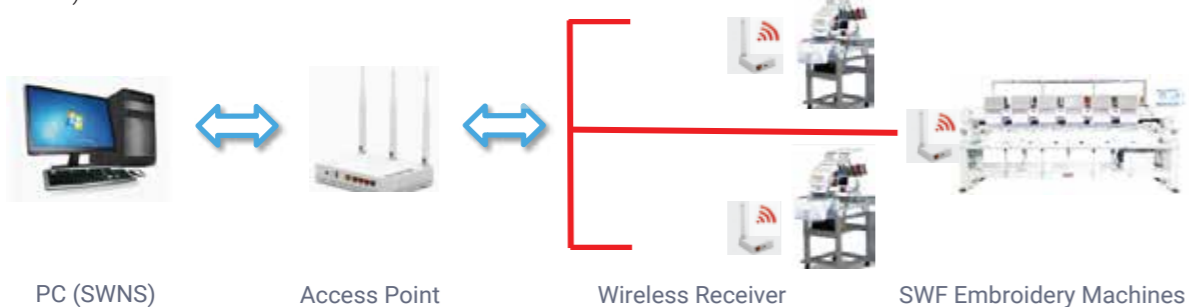

PC (SWNS)

Access Point

Wireless Receiver

SWF Embroidery Machines

\*The router (Access Point) and Wireless receivers are not included.

## Key Features

SWF

### 10.4 inch Full Touch LCD

10.4-inch touch screen Operation Panel, allows the user to easily view settings and embroidery status.

It offers many other advanced features including Free-Hand Stitch Function, Smart Embroidery System (SES), design selection per a needle, etc.



### Quick Change Cap Frame (Factory Option)

The Quick Change Cap Frame is designed to be User-Friendly, allowing easy switching between the cap frame and the tubular frame.

This system is more convenient and faster than the previous Cap Frame.

The Quick Change Cap Frame is SWF's unique and patent system.



### Tubular Frame

SWF KX Tubular has lots of options for tubular frame such as Tubular Round Frames and Tubular Square Frames with various sizes.



### Border Frame

Embroidery work available on fabric using the Lift-up table with aluminum Border frame.

Single Head machine : 520\*360mm  
 2 Head machine : 830 X 475mm  
 4 Head machine : 1,630(2,050) X 475mm  
 6 Head machine : 2,430(3,050) X 475mm  
 8 Head machine : 3,230(4,050) X 475mm

